



88069231

NOVEMBER 1995

IDAHO BUREAU OF LAND MANAGEMENT

TECHNICAL BULLETIN NO. 95-18

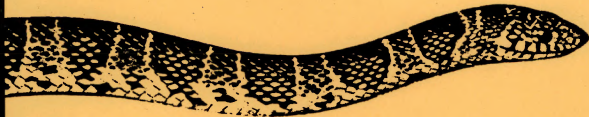

**MOVEMENTS AND HABITAT
SELECTION OF THE LONGNOSE
SNAKE (*Rhinocheilus lecontei*)
IN SOUTHWESTERN IDAHO**

by
Jonathan M. Beck and Charles R. Peterson
Department of Biological Sciences
Idaho State University
Pocatello, Idaho 83209

159-16

QL
84 . 2
. L352
no. 95-
18

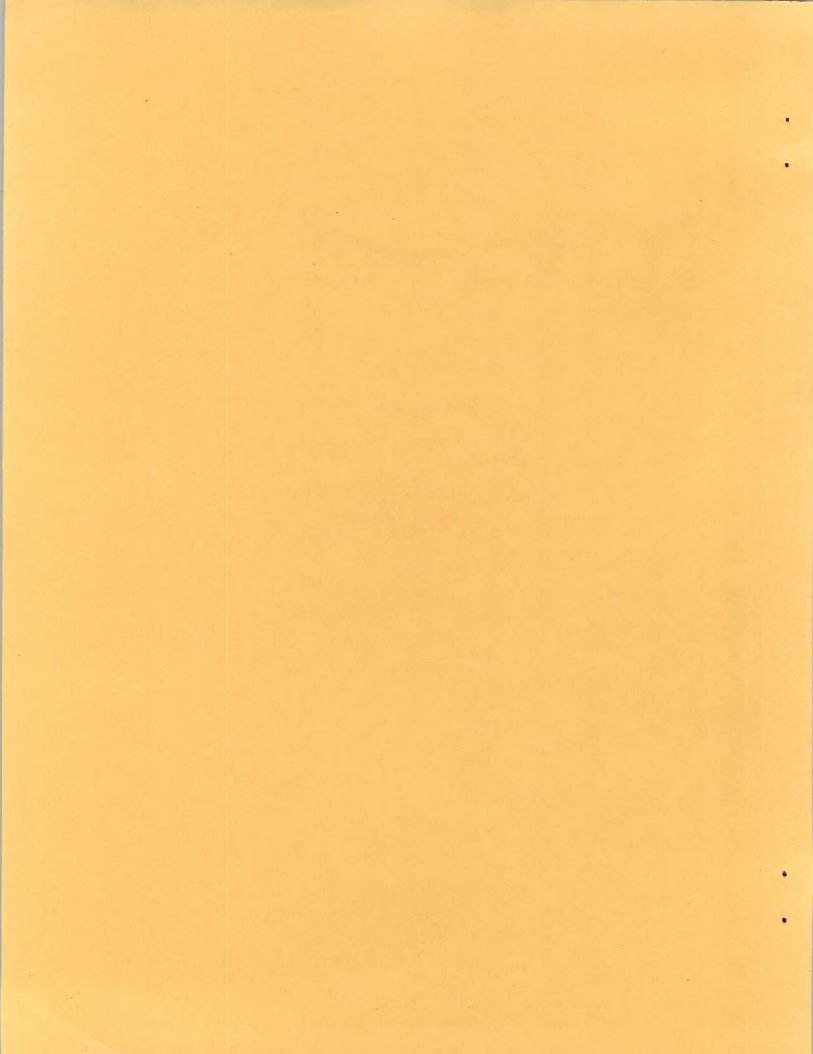

#34993468

ID 88069231

OL
84.2
.L352
no. 95-18

MOVEMENTS AND HABITAT SELECTION OF THE
LONGNOSE SNAKE (*Rhinocheilus lecontei*)
IN SOUTHWESTERN IDAHO



by:

Jonathan M. Beck and Charles R. Peterson

Department of Biological Sciences
Idaho State University
Pocatello, Idaho 83209

November 1995



EXECUTIVE SUMMARY

Movement and habitat selection studies are necessary for the conservation and proper management of reptile species. Such data are required when dealing with threatened, endangered, sensitive, or declining species to aid in the maintenance or recovery of that species. Because the Longnose Snake (*Rhinocheilus lecontei*) is listed in Idaho as a U.S.D.I. Bureau of Land Management Sensitive Species and as an Idaho Department of Fish and Game Species of Special Concern, we undertook this project to determine movement patterns and habitat selection of Longnose Snakes in southwestern Idaho. We used data from an extensive trapping survey that we conducted for Idaho Power Company to determine Longnose Snake macrohabitat use. We then used radiotelemetry to monitor movements and microhabitat use of three Longnose Snakes at Bruneau Dunes State Park. We measured microhabitat variables at each site where a snake was relocated (i.e., its location was redetermined) to quantify "used" microhabitat. We also measured microhabitat variables at randomly selected sites to obtain an estimate of the distribution of "available" microhabitat. To determine if Longnose Snakes were selecting certain microhabitat characteristics, we compared used to available microhabitat and tested for significant differences. We determined that Longnose Snakes at Bruneau Dunes State Park select retreat site habitats with burrows and shrub cover. Therefore, we feel that burrows and shrubs are an important aspect of Longnose Snake microhabitat and should be considered when managing for this sensitive species.



Longnose Snake (*Rhinocheilus lecontei*) captured at Bruneau Dunes State Park.

TABLE OF CONTENTS

EXECUTIVE SUMMARY	i
LONGNOSE SNAKE PHOTOGRAPH	ii
TABLE OF CONTENTS	iii
INTRODUCTION	1
METHODS	2
Study Area	2
Trapping	2
Movements	3
Microhabitat Measurements	3
Data Analysis	4
RESULTS	5
Trapping	5
Movements	4
Microhabitat Selection	5
DISCUSSION	6
Trapping	6
Movements	6
Microhabitat Selection	6
Management Implications	7
ACKNOWLEDGEMENTS	7
LITERATURE CITED	8
TABLES	10
FIGURES	12
APPENDIX 1 Macrohabitat categories and cover type definitions.	26
Appendix 1A Photograph of the Shrub Savanna Site.	27
Appendix 1B Photograph of the Forbland Site.	28
APPENDIX 2 1994 Shrub Savanna line intercept data.	29
APPENDIX 3 1994 Forbland line intercept data.	30

STATE OF TEXAS

COUNTY OF _____

IN SENATE,

January 1, 19__

REPORT

OF THE

COMMISSIONERS OF THE

LAND OFFICE

FOR THE YEAR

ENDING DECEMBER 31,

19__

BY _____

COMMISSIONER

LAND OFFICE

STATE OF TEXAS

LAND OFFICE

STATE OF TEXAS

LAND OFFICE

STATE OF TEXAS

LAND OFFICE

STATE OF TEXAS

LAND OFFICE

STATE OF TEXAS

LAND OFFICE

STATE OF TEXAS

LAND OFFICE

STATE OF TEXAS

LAND OFFICE

STATE OF TEXAS

LAND OFFICE

INTRODUCTION

Movement and habitat selection studies are necessary for the conservation and proper management of reptile species. The ecological reactions of reptiles to management practices are often highly site specific, depending on the details of the local environment. Therefore, site specific habitat and movement data need to be collected to construct predictive models of the effects of management practices on reptiles (Bury et., al. 1980). Unfortunately, the secretive nature of many snake species has resulted in a lack of data on movement and habitat selection (Reinert and Kodrich 1982). Such data are required when dealing with threatened, endangered, sensitive, or declining species to aid in the maintenance or recovery of that species. Because the Longnose Snake (*Rhinocheilus lecontei*) is listed in Idaho as a U.S.D.I. Bureau of Land Management Sensitive Species and as an Idaho Department of Fish and Game Species of Special Concern (Conservation Data Center 1994), we undertook this project to determine movement patterns and habitat selection of Longnose Snakes in southwestern Idaho.

A necessary requirement for any study of habitat utilization or habitat selection is to assess snake distributions in the environment accurately without observational bias in sampling (Reinert 1993). In the spring and summer of 1993 and 1994 we conducted an extensive trapping survey of the C.J. Strike Reservoir Area for Idaho Power Company to determine the distribution, abundance, and macrohabitat associations of the Night, Ground, and Longnose Snakes. In two field seasons, we installed 47 drift fence and funnel trap arrays over the length of the study area (Fig.1) in six different habitat types (Desertic Herbland/Forbland, Desertic Shrubland, Grassland, Shrubland, Shrub Savanna, and Talus) (See Appendix 1 for definitions of habitat types). We captured Longnose Snakes in four of the six habitat types (Desertic Herbland/Forbland, Desertic Shrubland, Shrubland, and Shrub Savanna). Common to all sites where we captured Longnose Snakes, were sandy to sandy loamy soils and a shrub component. Although we found that Longnose Snakes were selecting certain habitat patches, we did not know what specific features of that patch they were selecting.

The goal of this study was to determine microhabitat selection for Longnose Snakes in southwestern Idaho. To achieve this goal, we needed to accomplish the following specific objectives: (1) determine Longnose Snake movement patterns via radiotelemetry; (2) characterize individual Longnose Snake microhabitat use in the habitat patches where they were captured; (3) characterize microhabitat available in that habitat patch; and (4) compare used to available microhabitat to determine if microhabitat selection had occurred.

Because radiotelemetry provides concise information on the spatial biology of snake species (Reinert and Kodrich 1982), we used it to monitor the movements and microhabitat use of three Longnose Snakes within their larger habitat patches. Miniature, radiotransmitters were implanted into three Longnose Snakes at Bruneau Dunes State Park. We collected a series of habitat measurements around each relocation site (i.e., each site where the snake's location was redetermined) to characterize the site. The microhabitat around the relocated snake was considered as being used by that snake. Thus, radiotelemetry allowed us to monitor Longnose Snake movements and to determine Longnose Snake microhabitat use.

To determine if Longnose Snakes were selecting specific microhabitat characteristics, we compared the characteristics of the used microhabitat to the characteristics of available microhabitat. Available microhabitat was determined by measuring microhabitat variables at randomly selected sites. We then compared the used microhabitat to available microhabitat to look for differences. If significant differences were evident, then we concluded that microhabitat selection had occurred (Manly et.al. 1993).

This report provides: (1) relevant results from the trapping study undertaken for Idaho Power Company by Idaho State University; (2) results on microhabitat selection of Longnose Snakes; and (3) implications for Longnose Snake management. We feel the combined results of these projects will be useful in the management of Longnose Snakes in southwestern Idaho.

METHODS

Study Area

We conducted the trapping portion of the study for Idaho Power Company in the C.J. Strike Reservoir Area in southwestern Idaho. The study area was approximately 40 kilometers (25 miles) long, and is comprised of sections of the Snake and Bruneau Rivers (Fig. 1). The eastern boundary of the study area was Crane Rock and the western boundary was the Borden Lake Cooperative Wildlife Management Area. The study area was comprised of U.S.D.I Bureau of Land Management, Idaho Fish and Game, Idaho Power, and private lands.

We conducted the movements and microhabitat selection portion of this study at Bruneau Dunes State Park because it was the only site where we captured Longnose Snakes that were large enough to accommodate radiotransmitters. An added advantage was that Bruneau Dunes contained two relatively extensive patches of Desertic Herbland/Forbland (referred to as Forbland hereafter) and Shrub Savanna. From the trapping study, we knew that these macrohabitat types were being utilized by Longnose Snakes, and we wanted to see if there were specific microhabitat characteristics in these habitat types that were being selected (Fig. 2). See Appendix 1 for a description of Forbland and Shrub Savanna.

Trapping

We installed 44 drift fences with funnel traps in the six major habitat types occurring in the C. J. Strike Reservoir Area. Fifteen were installed during the first year (1993) and 29 were installed during the second year (1994). During the second year, we repeated three of the 1993 sites, so the total number of arrays used for trapping data analysis was 47. Each array consisted of four 7.5 m sections of 50.8 cm metal flashing arranged in a capital T configuration (Fig. 3). This array is a modified version of the trapping arrays proposed by Campbell and Christman (1982), Jones (1986), and Karns (1986).

We constructed funnel traps with fine enough hardware cloth (1/8", 3.2 mm) to prevent the escape of small snakes. One 91 cm x 61 cm piece of hardware cloth yields one trap body

(61 cm x 55 cm), one funnel (41 cm x 36 cm), and a door (15 cm x 23 cm); two additional funnels measuring 41 cm x 37.6 cm were cut from pieces of hardware cloth 91 cm x 37.6 cm. We rolled the 61 cm x 55 cm pieces of hardware cloth into cylinders and fastened them together with 1/8 inch (3.2 mm) pop rivets with rivet backs. The 41 x 36 cm pieces were rolled into funnels, pop riveted together, inserted into the ends of the trap bodies, and pop riveted into place. We then cut a doorway in the top of the trap to access animals without having to remove the trap from its place in the array. The edges of the doorway were covered with duct tape to prevent cutting ourselves or harming the animals when removing them from the trap. The door was secured to the trap body with wire, and hooks with rubber bands tied to them held the door shut. A completed trap measures approximately 95 cm x 17 cm, varying slightly due to differences that occurred during assembly (Fig. 3). To minimize trapping mortality, we outfitted each trap with an external cardboard or wood cover, provided an internal cardboard cover, and provided approximately three cm of soil substrate inside each trap (Lowell Diller, pers. comm.).

Movements

We used radiotelemetry to determine Longnose Snake movements. Miniature, 1.7 g BD-2GT Temperature-Sensing radiotransmitters (Holohil Systems LTD., Ontario, Canada) were surgically implanted into three Longnose Snakes that were large enough to accommodate the transmitter (snout-vent length 61-64 cm, mass 69-72 g). We allowed the snakes to recover from surgery for several days and then released them in the vicinity of the trapping array where they were captured. We relocated each individual every two to three days during the day. Each time a snake was relocated we marked the site with a colored flag showing the date of the relocation. When a snake moved, we measured the angle and distance between consecutive locations so we could plot movements.

Microhabitat Measurements

Used Microhabitat: We quantified the microhabitat at each site where a snake was relocated using quadrat and line intercept methods modified from Reinert (1984 a and b) for the desert environment. These sites will hereafter be referred to as snake location sites. A one meter square quadrat was centered over each snake location site (Fig. 4). In the quadrat, we counted or measured: (1) number of burrows, (2) burrow diameter, (3) number of shrubs, (4) shrub height, and (5) relative canopy closure (length x width of each shrub). We also collected line intercept data on four randomly selected one meter transects, inside the quadrat, to quantify the following: (1) bare ground, (2) litter, (3) moss, (4) forb cover, (5) grass cover, and (6) shrub cover.

In addition to the quadrat measurements, we collected data around each snake location site by randomly selecting four five-meter transects along a ten-meter axis that bisected the quadrat parallel to the trapping array where the snake was captured (Fig. 4). Along each five-meter transect, we counted or measured: (1) number of burrows, (2) burrow diameter, (3)

number of shrubs, (4) shrub height, and (5) relative canopy closure (length x width of each shrub) along a one-half meter strip on each site of the transect. We also collected the following line intercept data on the four randomly selected transects: (1) bare ground, (2) litter, (3) moss, (4) forb cover, (5) grass cover, and (6) shrub cover.

Available Microhabitat: We quantified available microhabitat by measuring the same microhabitat characteristics at randomly selected sites. Each time we collected data at a snake location site, we also measured microhabitat characteristics at a randomly chosen site. We used a random numbers table to generate a random distance (no less than ten meters and no greater than 350 meters) and a random angle from the snake location site. This provided us with an estimate of the distribution of available microhabitat to compare with the used microhabitat to determine if selection was occurring.

Data Analysis

Trapping: We calculated pooled capture rates per 100 trap nights for each site where we captured Longnose Snakes in 1993 and 1994. Capture rates were computed by dividing the total number of Longnose Snakes captured per site (including recaptures) by the total number of trap nights for that site. We generated bar graphs for comparison of capture rates between habitat types (Fig. 5).

The areas around all trapping arrays (1993 and 1994) were assigned to one of six macrohabitat classes (Appendix 1) by Dr. Antonie Holthuijzen (Idaho Power Company) using data collected at each trapping array by the Idaho Power field crew. Each site was assigned to a particular habitat cover type (Desertic Herbland, Desertic Shrubland, Grassland, Shrubland, Shrub Savanna, or Talus). We compared the number of arrays in each habitat type with the number of those habitats where Longnose Snakes were captured. By dividing the total number of trapping sites in each habitat class where Longnose Snakes occurred by the total number of sites where trapping was conducted for each habitat class and multiplying by 100 to standardize the index, we generated the probability (%) of trapping Longnose Snakes in each habitat type (Fig. 6).

Movements: We plotted each individual snake's movement pattern and generated individual home ranges using the convex polygon method. We used the convex polygon method because it is most commonly used to define animal activity ranges and therefore most comparable to previous studies (Reinert 1992). To test for directionality of each individual's movements we calculated Rayleigh's Z. Rayleigh's Z determined if the direction of each individual's movements were uniformly distributed around a circle (Zar 1984). If the sample is evenly distributed around the circle ($p > 0.05$) then there is no directionality in movements.

Microhabitat Selection: Although during our survey for Idaho Power we undertook possibly the largest reptile trapping effort in the state's history, we only captured three Longnose Snakes that could be used in this study. Because of the small sample size and high variance, it was impossible to generate an omnibus F statistic to determine if the used microhabitat was

significantly different than the available microhabitat. The snakes were also in different habitat types, Forbland and Shrub Savanna, so we could not justify pooling for analysis. Therefore, we reduced the microhabitat data to categorical data and plotted to see if differences were evident. We then analyzed the data, variable by variable, using Fishers Exact Test for 2x2 contingency tables and generated exact probabilities for Row x Column contingency tables (Conover 1971). We analyzed the quadrat data separately from the line intercept data.

RESULTS

Trapping

We captured Longnose Snakes in four of the six habitat types: Forbland, $P(c)= 22\%$, Desertic Shrubland, $P(c)= 29\%$, Shrubland, $P(c)= 10\%$, and Shrub Savanna, $P(c)= 29\%$ (Fig. 6). All areas where we captured Longnose Snakes were upland sites with sandy to sandy loam soils that had some shrub component at the site. Capture rates were highest in Shrub Savanna, followed by Desertic Shrubland, Desertic Herbland and Shrubland (Fig. 5).

Movements

We telemetered three Longnose Snakes (snakes # 11, 5, and 6) at Bruneau Dunes State Park during the summers of 1993 and 1994 (Table 1). Snake #11 was radio-tracked at the Shrub Savanna site from 28 July 1993 to 11 September 1993, but we were unable to relocate it after the winter of 1993. Snake #11 had a home range of 15,337 m² (Fig. 7). Snake # 6 was captured at the same Shrub Savanna site in 1994 and we tracked its movements from 7 July 1994 to 25 September 1994. Snake # 6 had a home range of 73,494 m² (Fig. 8). Snake # 5 was tracked from 7 July 1994 to 25 September 1994. Snake # 5 had a home range of 30,845 m² (Fig. 9). None of the snakes demonstrated directionality in their movements (Figs. 10, 11, and 12).

Microhabitat Selection

We detected significant differences in four of the eleven microhabitat variables between used and available quadrats (Table 2). At the Shrub Savanna site, none of the random quadrats had any burrows or shrubs, while three of the snake location sites had burrows and two of the sites had shrubs. Therefore, there were differences between the used and available microhabitat. The snake in the Shrub Savanna habitat at Bruneau Dunes State Park selected sites with Burrows and Shrubs (Fig. 13). There were no other significant differences between available and used variables at this site. At the Forbland site, the number of burrows at used and available microhabitat appears to be different when plotted as a histogram (Fig. 14A) (Fishers Exact Test $p = 0.057$). Forbland quadrat data also indicated that burrow diameter at snake location sites was significantly different from burrow diameter at random sites ($p = 0.003$). The snake in the Forbland habitat types selected sites with burrows in the 1-3 cm range or larger.

We also detected significant differences in two of the eleven transect microhabitat variables collected at the Forbland site (Fig. 14 C and D). The number of burrows and shrub height at the snake location sites were significantly different than the number of burrows and shrub height at random sites ($p = 0.007$ and 0.024 respectively) (Appendix 2 and 3).

DISCUSSION

Trapping

During the two year study for Idaho Power Company, no Longnose Snakes were ever captured in rocky areas on the rim or adjacent to talus. This suggests a greater association with shrub or herbland habitat types than with rocky areas. However, in a study conducted between 1977 and 1980 by Diller and Wallace (1981) in southwestern Idaho, Longnose Snakes were reported to be collected in rocky as well as the shrub and herbland habitat types.

Movements

Our movement data suggest that Longnose Snakes at Bruneau Dunes tend to remain in an area if they are in appropriate habitat. Longnose Snakes appear to be moderate movers (hundreds of meters), when compared to Western Rattlesnakes (*Crotalus viridis*) that have moves of over a kilometer (Cobb 1994). The relatively small home ranges of each individual Longnose Snake suggest that when a snake is in appropriate habitat it tends to stay there. However, Longnose Snakes are crepuscular to nocturnal and we were unable to track individual snake movements continuously to see if they were making forays out of the reported home range area during the night.

Microhabitat Selection

Our microhabitat data indicate that sites with shrubs were selected by the Longnose Snakes in the Shrub Savanna and Forbland habitat types. Our quadrat data also indicate that sites with burrows were selected by the snake in the Shrub Savanna habitat type and suggest that burrows were selected in the Forbland site. We feel the marginally significant result from the quadrat measurements was an artifact of the sampling method. Each time a snake was relocated it was in a burrow, and a quadrat was centered over the site. The opening to the burrow was not always in the quadrat, and therefore, some quadrat counts at snake relocation sites contained no burrows. We feel the line intercept data are more indicative of what is happening at the Forbland site. These data indicate that Longnose Snakes in the Forbland habitat type select sites with many burrows.

Our results are consistent with what is reported in the literature for this species. Longnose Snakes are a crepuscular to nocturnal snake that uses burrows (Diller and Johnson 1982; Nussbaum et.al. 1982; Stebbins 1985). Because Longnose Snakes are nocturnal, they

use burrows during the day. The extensive mammal burrow systems at both sites in the park provide retreat sites away from the extreme surface temperatures and some predators.

Management Implications

Macrohabitat Management: A prerequisite for the proper management of any species is knowledge of its distribution, relative abundance, and habitat associations in the area to be managed. After two years of intense trapping and vegetation measurements, we have an increased understanding of these three parameters for Longnose Snakes in the C.J. Strike area. We have identified one factor that may be having a negative influence on the reptile populations in the study area; the conversion of native bunchgrass and shrub habitats to exotic grasslands or agriculture. We did not capture target species in any of our trapping sites situated in exotic grassland.

Microhabitat Management: Because we were relocating each individual during the day, we actually determined retreat site microhabitat selection. Because Longnose Snakes spend most of their time in retreat, these sites are especially important. Therefore, we conclude that burrows and shrub cover are an important aspect of Longnose Snake habitat and should be protected when managing for this Sensitive Species in southwestern Idaho.

ACKNOWLEDGEMENTS

We would like to thank The Idaho Bureau of Land Management and Idaho Power Company for financial and logistical support, without which this project would not have been possible. We would especially like to thank Allan Ansell and Anthonie Holthuijzen of Idaho Power Company for allowing us to use the 1993 and 1994 Longnose Snake trapping data from the C.J. Strike study in this report. Many other people helped: Idaho Department of Fish and Game gave us permission to conduct this study; Idaho Department of Fish and Game, Jerome office, provided financial support; Kelly Wilde, Holly Hovis, Rob Marsh, Peter Peconi, Von Pope, and Craig Rebish provided assistance in the field or collected vegetation data at each trapping array; Holly Hovis provided her plant knowledge and moral support; Bill Doering assisted with data collection; Dick Wallace provided expert advice; Lowell Diller helped to get the trapping study off the ground; Mike Dorcas assisted with snake surgeries; and Wess Witworth of Bruneau Dunes State Park gave us permission to work in the park.

LITERATURE CITED

Bury, R.B., H.W. Campbell., and N.J. Scott. 1980. Role and importance of nongame wildlife. Transactions of North American Wildlife and Natural Resources Conference. 45:197-207.

Campbell, H. W., and S. P. Christman. 1982. Field techniques for herpetofaunal community analysis. pp. 193-200. In: Scott, N. J., Jr. ed. Herpetological communities. U.S. Fish and Wildlife Service Wildlife Research Report 13, Washington, D. C., USA.

Cobb, V. A. 1994. The ecology of pregnancy in free-ranging Great Basin Rattlesnakes (*Crotalus viridis lutosus*). Pocatello: Idaho State University. Dissertation.

Conover, W. J. 1971. Practical nonparametric statistics 2ed. New York: John Wiley and Sons.

Conservation Data Center. 1994. Rare, threatened, and endangered plants and animals of Idaho. Third edition. Idaho Department of Fish and Game, Boise, Idaho. 39p.

Diller, L. V., and D. R. Johnson. 1982. Ecology of the reptiles in the snake river birds of prey area. U.S. Department of Interior Bureau of Land Management snake river birds of prey research project Boise, Idaho.

Diller, L. V., and R. L. Wallace. 1981. Additional records and abundance of three species of snakes in southwestern Idaho. The Great Basin Naturalist 41(1):154-157.

Jones, K. B. 1986. Amphibians and reptiles. pp. 267-290. In: Cooperrider, A. Y., R. J. Boyd, and H. R. Stuart (eds.), Inventory and monitoring of wildlife habitat. U.S. Department of Interior Bureau of Land Management Service Center, Denver, Co. 858 pp.

Karns, D. K. 1986. Field herpetology: methods for the study of amphibians and reptiles in Minnesota. James Ford Bell Museum of Natural History occasional paper: number 18. pp 25-88. University of Minnesota, Minnesota.

Manly, B.; McDonald, E.; D. Thomas. 1993. Resource selection by animals. Boundary Row, London: Chapman Hall.

Nussbaum, R. A., Brodie, E. D., Jr., and R. M. Storm. 1983. Amphibians and reptiles of the Pacific Northwest. Moscow, ID: University Press of Idaho.

Reinert, H. K. and W. K. Kodrich. 1982. Movements and habitat utilization by the Massasauga, *Sistrurus catenatus catenatus*. Journal of Herpetology. 16:162-171.

Reinert, H. K. 1984a. Habitat separation between sympatric snake populations. *Ecology*. 65:478-486.

Reinert, H. K. 1984b. Habitat variation within sympatric snake populations. *Ecology*. 65:1673-1682.

Reinert, H. K. 1992. Radiotelemetric field studies of field pitvipers: data acquisition and analysis. pp. 185-197. *In*: Campbell, J. and E. D Brodie Jr. (eds.), *Biology of the Pitvipers*. Selva. Tyler Texas.

Reinert, H. K. 1993. Habitat selection in snakes. pp.201-240. *In*: Seigel, R.A., and J.T. Collins (eds.), *Snakes Ecology and Behavior*. McGraw Hill. New York.

Stebbins, R. C. 1985. *Western reptiles and amphibians*. Boston: Houghton Mifflin Company.

Zar, J. H. 1984. *Biostatistical Analysis*. Englewood Cliffs, NJ: Prentice-Hall, Inc.

Table 1. Distances moved and dates of detection for each Longnose Snake's movements.

Move #	Angle moved	Distance moved(m)	Date of move Detection	Number of Days at Same Site
Shrub Savanna 1994				
Released	no move	no move	07-Jul-94	12
1	129	143	25-Jul-94	?
2	30	21	29-Jul-94	?
3	192	197	04-Aug-94	?
4	30	74	12-Aug-94	9
5	271	301	05-Sep-94	?
6	161	226	17-Sep-94	8
**Recaptured 14 October 1994				
Forbland 1994				
Released	Released	Released	07-Jul-94	2
1	208	122	09-Jul-94	6
2	170	47	19-Jul-94	?
3	135	182	25-Jul-94	?
4	119	110	29-Jul-94	?
5	288	140	04-Aug-94	?
6	331	132	12-Aug-94	?
7	14	128	17-Aug-94	?
8	235	75	21-Aug-94	?
9	145	120	05-Sep-94	20
Shrub Savanna 1993				
Released	Released	Released	28-Jul-93	
1	159	17	28-Jul-93	2
2	240	70	02-Aug-93	2
3	358	113	05-Aug-93	?
4	146	147	10-Aug-93	?
5	330	137	11-Aug-93	?
6	264	5	14-Aug-93	?
7	330	8	17-Aug-93	?
8	108	194	21-Aug-93	4
9	242	194	02-Sep-94	9

Table 2. 1994 Shrub Savanna and Forbland one meter quadrat data.

Site	# Burrows	Brw. Dia. (cm)	# Shrubs	Ht. (cm)	Canopy(cm ²)	Bare (cm)	Litter (cm)	Moss(cm)	Forbs(cm)	Grass (cm)	Shrubs (cm)
Shrub Savanna 1994 Quadrat											
Used	0	0,0	0	0	0	22	188	0	0	190	0
Used	4	3,1,4,5,3	1	99	7252	48	260	0	33	59	0
Used	3	3,3,4	1	173	45750	0	123	0	4	2	271
Used	0	0,0	0	0	0	61	304	0	0	35	0
Used	0	0,0	0	0	0	245	132	0	23	0	0
Used	0	0	0	0	0	179	201	0	17	3	0
Used	1	2	0	0	0	10	239	0	10	141	0
Random	0	0	0	0	0	115	135	0	0	50	100
Random	0	0	0	0	0	79	229	35	57	0	0
Random	0	0	0	0	0	102	149	0	31	118	0
Random	0	0	0	0	0	52	213	0	0	135	0
Random	0	0	0	0	0	18	341	0	41	0	0
Random	0	0	0	0	0	151	169	0	21	46	0
Random	0	0,0	0	0	0	53	304	0	4	39	0
Forbland 1994 Quadrat											
Used	6	5,3,3,4,3,3	0	0	0	173	164	3	29	31	0
Used	3	2,1,3	1	35	2144	192	169	0	0	39	0
Used	2	7,1	2	69,64	4800,2100	94	86	0	14	0	206
Used	3	7,2,2	1	74	18	129	146	48	0	0	77
Used	4	7,7,2,3	0	0	0	128	187	67	0	0	18
Used	0	0,0	0	0	0	332	39	0	29	0	0
Used	1	5,0	1	63	8740	0	102	0	3	0	295
Used	1	9,0	0	0	0	252	51	3	30	64	0
Used	0	0,0	0	0	0	110	207	0	20	63	0
Random	0	0	0	0	0	24	292	0	55	29	0
Random	0	0	0	0	0	238	57	0	34	71	0
Random	5	2,2,2,3,3	0	0	0	202	99	11	19	69	0
Random	1	5	0	0	0	298	50	43	6	3	0
Random	0	0	2	22,24	144,432	235	78	53	0	0	34
Random	0	0	0	0	0	220	110	0	49	21	0
Random	0	0	0	0	0	190	137	0	9	64	0
Random	0	0	0	0	0	118	220	0	22	14	26
Random	0	0	0	0	0	9	0	0	0	391	0

C. J. Strike Reservoir, Idaho

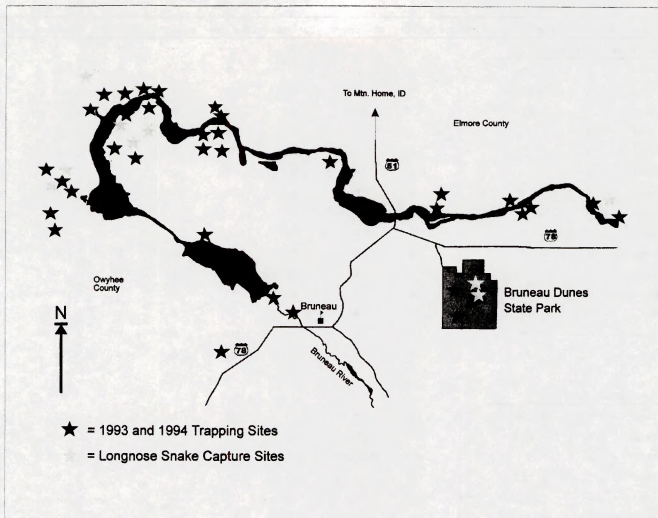
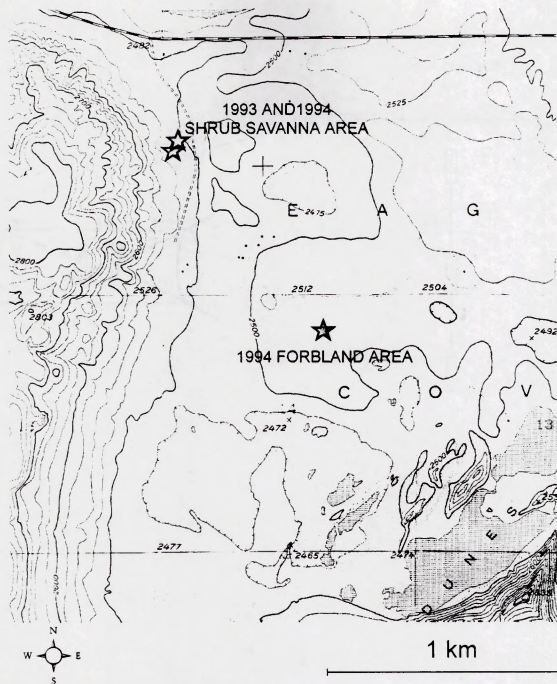

Figure 1. Longnose Snake distribution in the C.J. Strike Reservoir Area. Black stars represent trapping locations, and gray stars indicate sites where Longnose Snakes were captured.

BRUNEAU DUNES, IDAHO BRUNEAU DUNES STATE PARK



★ = Longnose Snake activity center

Figure 2. 1993 and 1994 Longnose Snake activity centers at Bruneau Dunes State Park. The map was scanned from the Bruneau Dunes Quadrangle Idaho, 7.5 minute series (Topographic) 1978 map. The red stars correspond to the activity areas in each habitat type for each telemetered Longnose Snake.

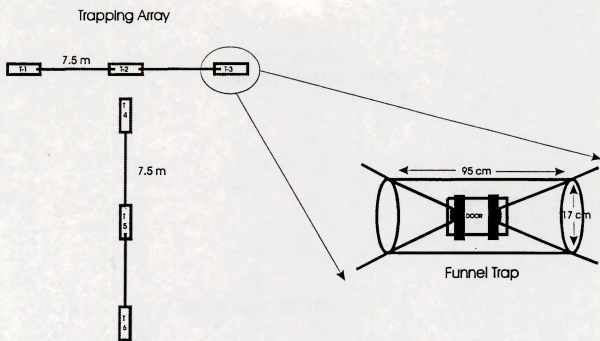

Figure 3. Schematic diagram of the "T" trapping array and funnel trap used during the 1993 and 1994 trapping seasons at C.J. Strike.

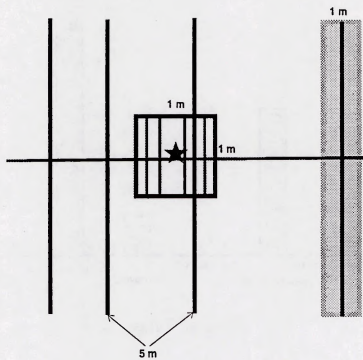

Figure 4. A representation of the 1m x 1m vegetation sampling quadrat located over a relocated snake (star) with the four, five meter transects. The shaded area represents the meter strip census. Not drawn to scale.

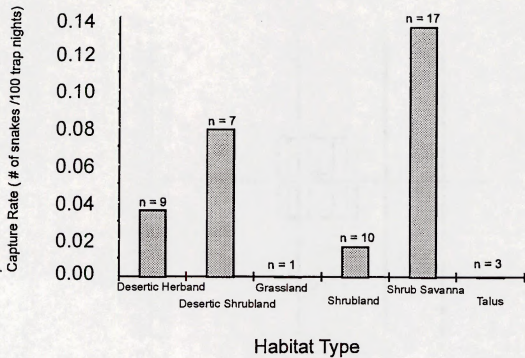

Figure 5. Average Longnose Snake capture rates for each habitat type sampled at C. J. Strike Reservoir during the spring and summer of 1993 and 1994. n = number trapping arrays in each habitat type.

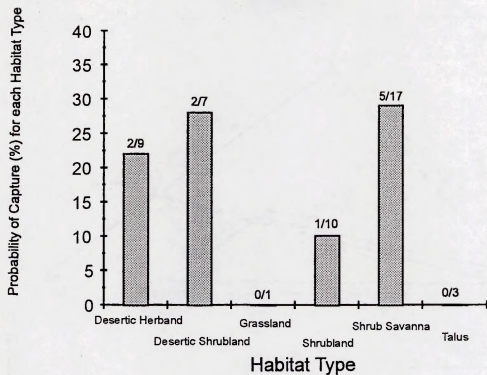
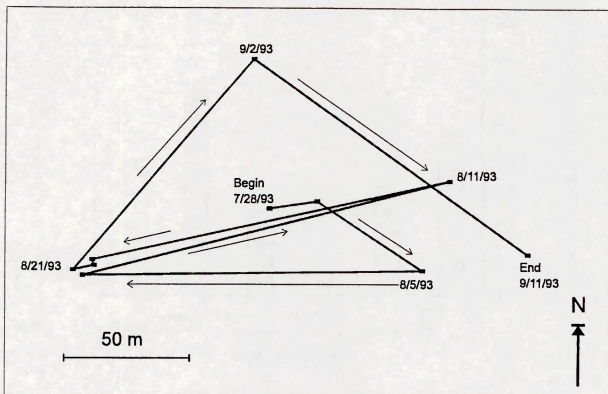

Figure 6. Probability of capturing a Longnose Snake in each habitat type sampled at C. J. Strike Reservoir during the spring and summer of 1993 and 1994. Fractions represent the number of sites where Longnose Snakes were captured over the total number of sites trapped in each habitat type.

Movements of Longnose Snake # 11
Bruneau Dunes Shrub Savanna 1993



Convex Polygon Home Range:

15337 m²

0.015337 km²

Figure 7. Movements and home range of Longnose Snake # 11 at the 1993 Shrub Savanna site. The arrows represent assumed direction of movement.

Movements of Longnose Snake # 6
Bruneau Dunes Shrub Savanna 1994

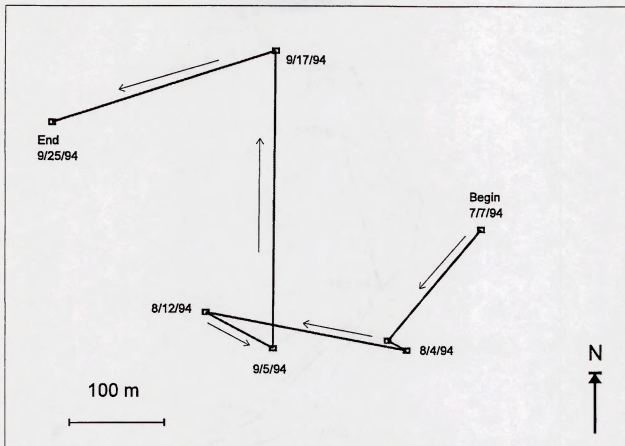

Convex Polygon Home Range:

73494 m²

0.073494 km²

Figure 8. Movements and home range of Longnose Snake # 6 at the 1994 Shrub Savanna site. The arrows represent assumed direction of movement.

Movements of Longnose Snake # 5 Bruneau Dunes Forbland 1994

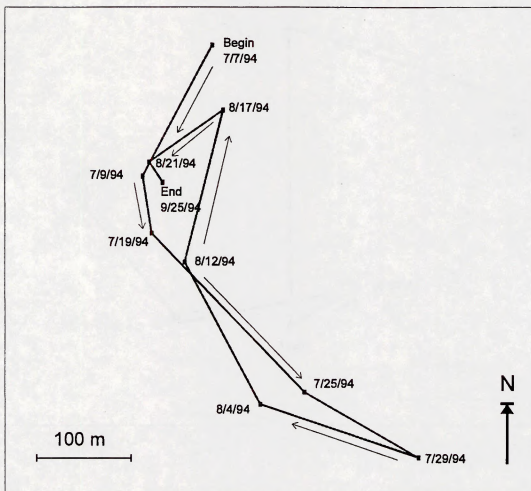

Convex Polygon Home Range:

30845 m²

0.030845 km²

Figure 9. Movements and home range of Longnose Snake # 5 at the 1994 Forbland site. The arrows represent assumed direction of movement.

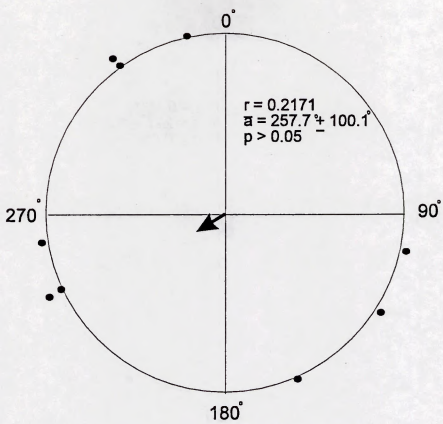

Figure 10. Circular scattergram of Longnose Snake # 11's movements in the 1993 Shrub Savanna habitat. Snake # 11 exhibited no directionality in its movements.

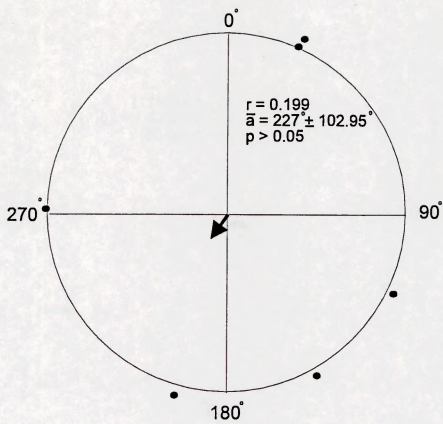

Figure 11. Circular scattergram of Longnose Snake # 6's movements in the 1994 Shrub Savanna habitat. Snake # 6 exhibited no directionality in its movements.

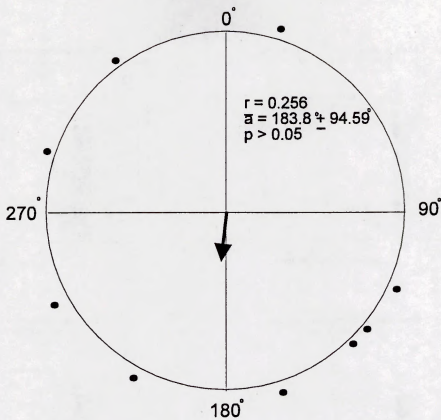

Figure 12. Circular scattergram of Longnose Snake # 5's movements in the 1994 Forbland habitat. Snake # 5 exhibited no directionality in its movements.

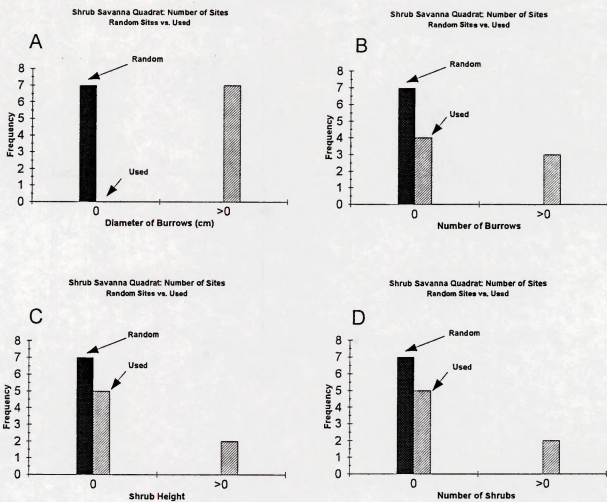

Figure 13. Comparison of available and used quadrat habitat characteristics at the Shrub Savanna site. There were significant differences in burrow diameter (A), number of burrows (B), shrub height (C), and number of shrubs (D) between used and random sites because all random sites had counts of zero.

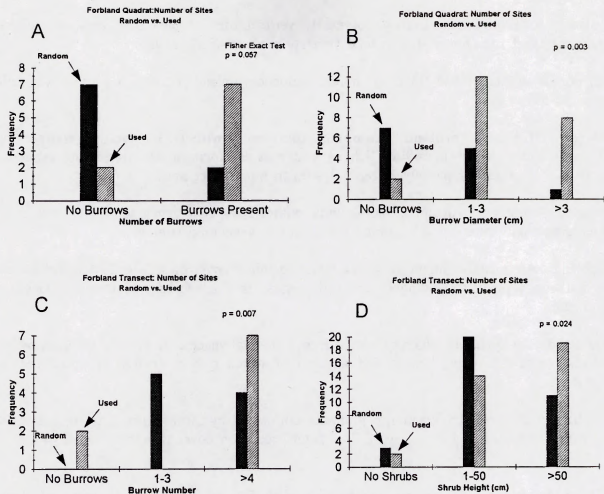

Figure 14. Comparison of available and used quadrat and transect habitat characteristics at the Forbland site. There were moderately significant differences in number of burrows (A), and significant differences in burrow diameter (B) for the quadrat data. There were also significant differences in burrow number (C), and shrub height (D) for the line transect data.

Appendix 1. Macrohabitat categories and definitions of cover types used during 1993 and 1994. Type in bold indicates macrohabitats used in this study.

Adjacent to Talus/Cliff: Consists of nearly vertical rock or bare soil faces, or slopes of unconsolidated rock material with total vegetation cover of 5% or less.

Barren: Is an undisturbed (by direct human influence) upland area that has a total vegetation cover of 5% or less.

***Desertic Herbland/Forbland: An upland community with 1-25% total vegetation cover of non-woody plants (including lichens and mosses) forming the dominant vegetation stratum. It includes sparsely vegetated sites in non-desert areas.**

Desertic Shrubland: An upland community with 1-25% total vegetation cover with shrubs (including small trees < 5 m) forming the dominant vegetation stratum.

Forbland: An upland community with a total vegetation cover of at least 25% and dominated by non-woody plants (including lichens and mosses) of which forbs (native or introduced) are dominant.

Grassland: An upland community with at least 25% total vegetation cover, dominated by non-woody plants (including lichens and mosses) of which grasses (native or introduced) are dominant.

Shrubland: An upland vegetation community dominated by shrubs (including small trees < 5 m) with a shrub canopy of at least 25%. Total vegetation cover is greater than 25 %.

***Shrub Savanna: An upland community with 5% to 25% canopy cover of shrubs (including small trees < 5 m). Total vegetation cover is at least 25%, and the area between shrubs is typically dominated by grasses or other herbaceous vegetation.**



Appendix 1.A. Photograph of the 1993 and 1994 Shrub Savanna Site.



Appendix 1B. Photograph of the 1994 Forbland Site.

Appendix 2. 1994 Shrub Savanna line intercept data.

Site	# Burrows	Brw. Dia. (cm)	# Shrubs	Ht. (cm)	Canopy(cm ²)	Bare (cm)	Litter (cm)	Moss(cm)	Forbs(cm)	Grass (cm)	Shrubs (cm)
Shrub Savanna 1994 Line Transect											
Used	6	2,16,3,3,9,2,5	1	113.0	1440	339	549	198	104	614	190
Used	3	1,4,5,2	5	83,100,92,92,100	5146,10712, 4290,136,7200	254	1229	22	75	280	140
Used	2	4,2	2	120,170	4350,21600	320	940	0	382	101	257
Used	1	4	0	0.0	0	346	903	0	242	509	0
Used	13	3,2,12,2,3, 2,2,2,2,3,1,2,1	0	0.0	0	743	881	0	91	30	255
Used	5	6,8,6,6,4	0	0.0	0	627	957	0	192	224	0
Used	2	6,4	0	0.0	0	12	1729	0	5	254	0
Rand	0	0.0	2	185,147	374,768	85	530	0	140	1245	0
Rand	1	2.0	0	0	0	666	1062	0	272	0	0
Rand	6	3,4,2,1,2,8	2	100,125	20140,16000	673	779	50	16	325	158
Rand	4	4,4,1,1,5	3	95,139,104	7056,21140,11948	62	426	79	442	529	462
Rand	0	0	6	120,80,150, 110,124,120	15000,7000,5000, 4000,5600,8400	126	1303	84	38	449	0
Rand	3	4,5,3	0	0	0	937	821	0	166	27	0
Rand	3	3,4,9	0	0	0	952	465	0	576	7	0

Appendix 3. 1994 Forbland line intercept data.

Site	# Burrows	Brw. Dia. (cm)	# Shrubs	Ht. (cm)	Canopy(cm ²)	Bare (cm)	Litter (cm)	Moss(cm)	Forbs(cm)	Grass (cm)	Shrubs (cm)
Shrub Savanna 1994 Line Transect											
Used	0	0	0	0	0	987	521	59	255	178	0
Used	7	2,8,4,7,6,3,4	8	39,96,100,15, 54,108,75,100	4275,7400,152,1496, 7332,2700,4700,4572	807	509	317	33	283	51
Used	4	3,3,4,7	8	92,68,69,66, 36,70,50,57	9506,9024,6935,19364, 925,14950,1680,5344	812	637	25	136	255	135
Used	4	3,4,5,8	2	88,63	516,2822	612	672	509	73	39	95
Used	4	5,2,2,5	4	50,48,45,73	1500,840,740,9100	973	519	252	93	73	90
Used	5	4,3,7,3,5	0	0,0	0	846	540	0	559	55	0
Used	5	3,9,4,2,7	2	40,58	360,2052	835	662	129	221	153	0
Used	6	2,3,3,1,2,3	5	45,68,50,33,19	1425,2176,620,120,352	1020	489	6	232	206	47
Used	0	0,0	4	67,33,31,64	7154,2021,6480	794	560	188	64	257	137
Rand	6	1,5,11,8,11,1,9	0	0	0	559	527	0	670	244	0
Rand	2	5,4	0	0	0	986	483	43	50	429	9
Rand	4	4,3,3,4	6	81,23,50, 45,92,17	1904,527,1219,2244, 14880,2680	617	674	66	322	63	258
Rand	13	4,3,2,2,2,2, 5,5,6,2,7,5,7	11	100,70,34,6,20,32,4 5,50,44,30,38	22100,24700,1147,2000,840, 408,810,2400,1520,1600,2150	1015	441	205	20	0	319
Rand	1	2	7	68,40,44, 43,41,30,41	3420,1176,2146,1296, 1225,360,1242	594	542	503	119	77	165
Rand	4	2,3,3,2	5	125,127,140, 140,56	1312,44400,44400, 9191,8316	568	826	49	83	226	248
Rand	1	6	0	0	0	1030	508	0	364	49	49
Rand	3	1,3,6	2	30,45	840,1610	1310	275	115	228	72	0
Rand	2	4,2	1	74	180	0	56	0	0	1896	48





Bureau of Land Management
Idaho State Office
3380 Americana Terrace
Boise, Idaho 83706

BLM/ID/PT-96/002+1150